

PYD
ELECTROBOMBAS

SERIE

TIGER

INOX

**GAMA
ACHIQUE**

SEWAGE PUMPS
POMPES DE RELEVAGE

PASO DE SÓLIDOS HASTA 45 mm

SOLIDS SIZE UP TO 45 mm
SOLIDES JUSQU'À 45 mm

CATÁLOGO TÉCNICO



Bombas sumergibles para aguas residuales que puede bombear y drenar aguas residuales con sólidos en suspensión de hasta 50 mm. Este producto es capaz de procesar agua de pozos negros, piscinas, de procesos industriales y aguas residuales sanitarias, así como para sistemas de alcantarillado. Incluye condensador y boya.

Stainless steel submersible sewage pumps that can pump and drain sewage with suspended solids, and the solid size can be as large as 50 mm. It's able to empty cesspits and pools, process industrial and sanitary waste water, and it's also suitable for the draining of sewage systems. It comes with capacitor and float switch.

Pompe immergée inox pour pomper et drainer les eaux usées avec des solides en suspension, dont la taille peut être de 50 mm de largeur. C'est capable de vider les puisards et piscines, de traiter les eaux usées sanitaires et industrielles et est adaptée au drainage de systèmes d'égout. Avec condensateur et interrupteur flottant.



MATERIALES

Cuerpo bomba	INOX 304
Eje rotor	INOX 304
Soporte motor	INOX 304
Impulsor	INOX 304
Cierre mecánico	Cer/graf.

RANGO DE TRABAJO

Protección	IP 68
Aislamiento	Clase E
Inmersión máx.	5 m
Temperatura	0 - 40°C
Fluidos	Residuales

MATERIALS

Pump body	SS 304
Rotor shaft	SS 304
Motor support	SS 304
Impeller	SS 304
Mechanical seal	Cer/graph.

WORKING RANGE

Protection	IP 68
Isolation	Class E
Max. depth	5 m
Temperature	0 - 40°C
Fluids	Waste water

MATÉRIELS

Corps pompe	INOX 304
Arbre	INOX 304
Support moteur	INOX 304
Roue	INOX 304
Garniture méc.	Cer/graph.

PLAGE DE TRAVAIL

Protection	IP 68
Isolement	Class E
Immersion max.	5 m
Température	0 - 40°C
Fluides	Eaux usées

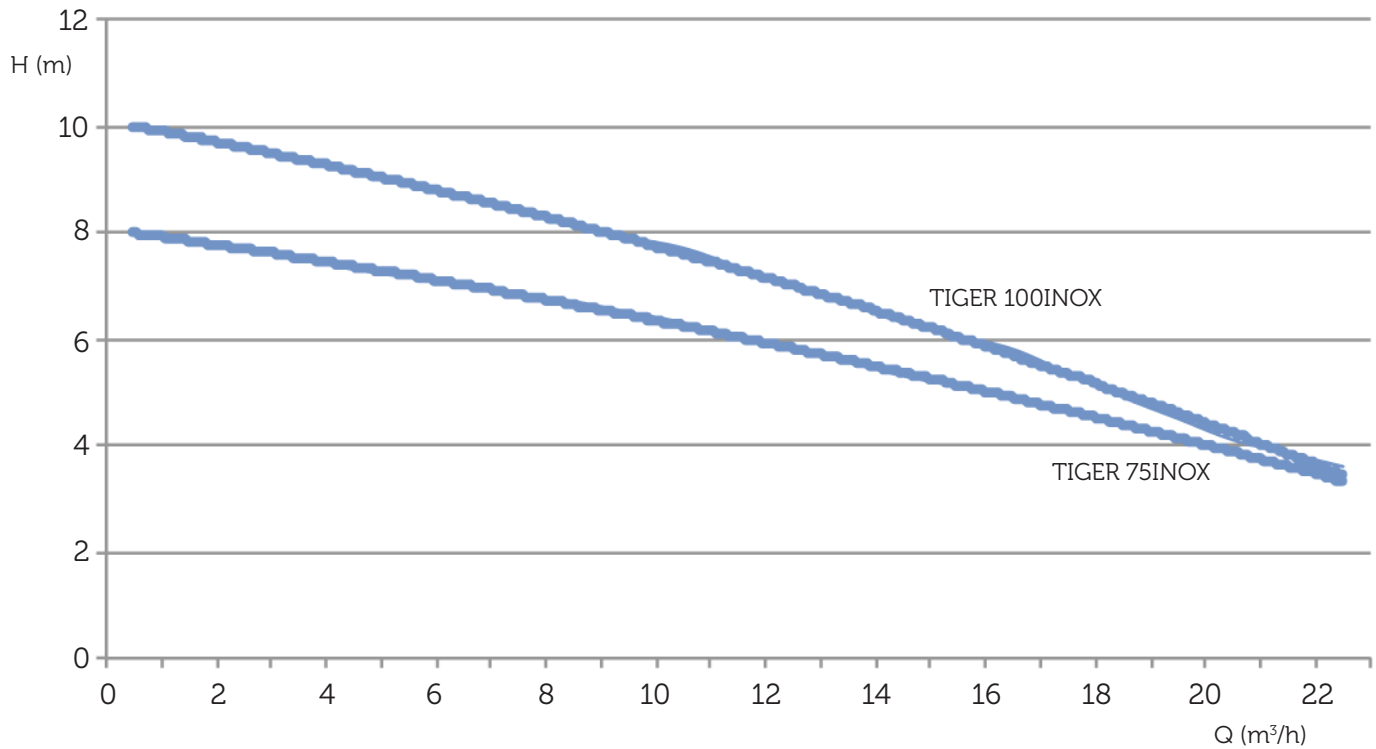

MODELO MODEL MODÈLE	DN [Ø']	SÓLIDOS SOLIDS SOLIDES [mm]	INTENSIDAD [A] CURRENT [A] INTENSITÉ [A]		POTENCIA POWER PUISSANCE		CONDENSADOR CAPACITOR CONDENSATEUR [µF]
			1~220V	3~400V	KW [P ₂]	Hp [P ₂]	
TIGER 75INOX	2	35	4,2	-	0,55	0,75	20
TIGER 100INOX	2	50	5,2	-	0,75	1,0	25

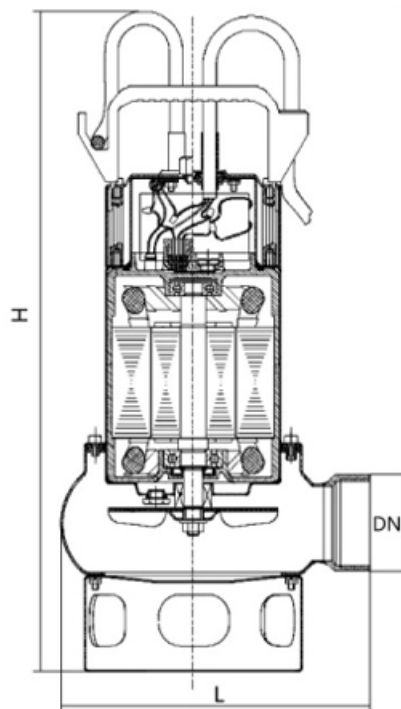

MODELO MODEL • MODÈLE	L	H	DN	Kg
TIGER 75INOX	210	450	51	9,5
TIGER 100INOX	220	480	51	10,6

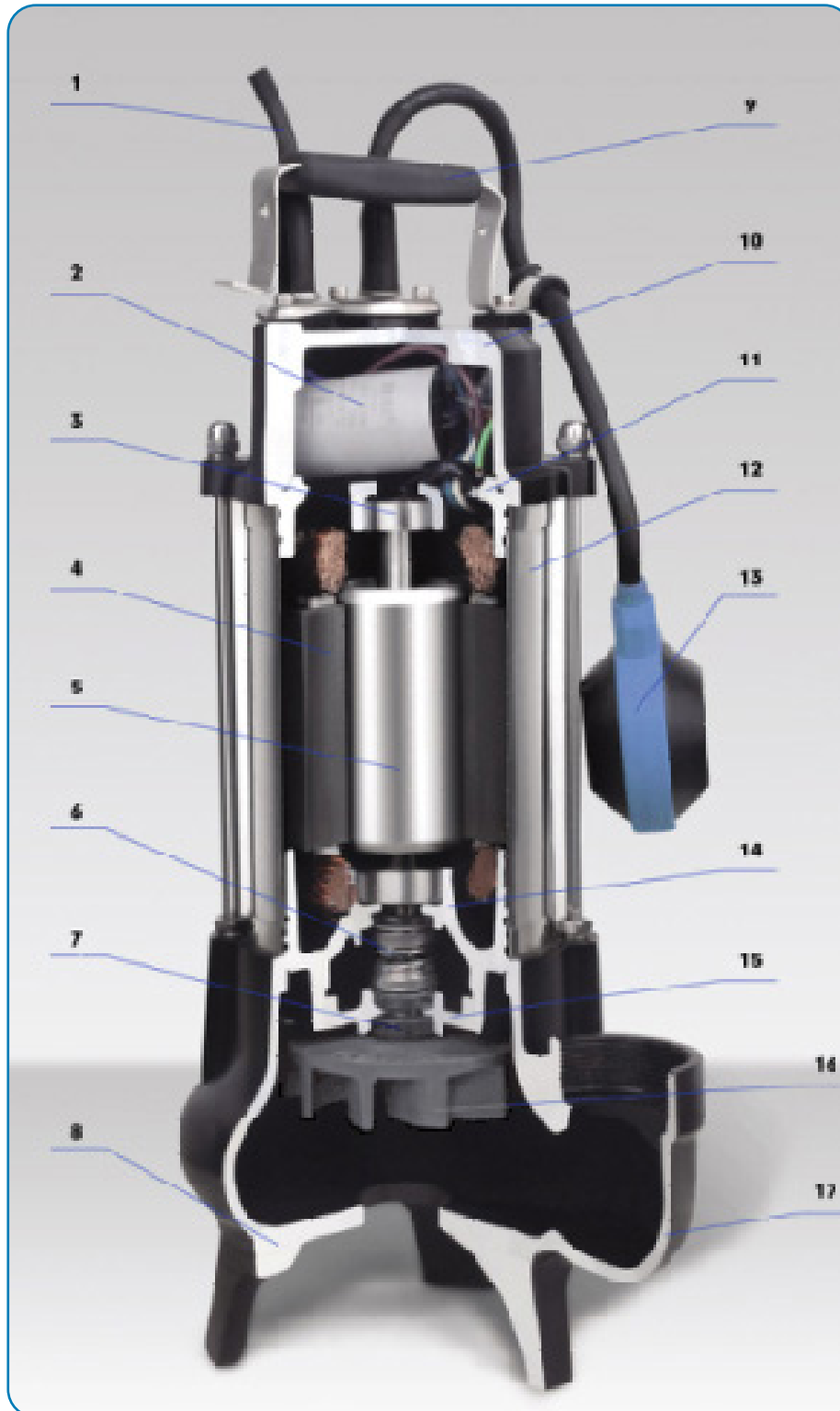

No.	Description	No.	Description	No.	Description
1	Cable	7	Framework oil seal	13	Float switch
2	Capacitor	8	Bottom case	14	Oil chamber
3	Deep groove ball bearing	9	Handle	15	Oil chamber cover
4	Stator winding	10	Top cover	16	Impeller
5	Rotor	11	Upper bearing block	17	Pump body
6	Mechanical seal	12	Motor bracket		

Proindecsa

Polígono Industrial Oeste, parc. 25/12

30169 San Ginés (Murcia)

Tlf: 968 88 08 52 Fax: 968 09 84

www.proindecsa.com / proindecsa@proindecsa.com



entidad asociada a

cepreven

PYD
ELECTROBOMBAS

PYD
INDUSTRIA

PYD
SYSTEM

PYD
SUMERGIDAS